

Z-Line Steel Shelf Unit

RETAIN INSTRUCTIONS FOR FUTURE REFERENCE



**LOAD CAPACITIES
PER SHELF LEVEL***

SOLID STEEL SHELVES

UNIT SIZE	WT. CAPACITY
36w x 12d	750 lbs.
36w x 18d	750 lbs.
36w x 24d	700 lbs.
36w x 36d	600 lbs.
42w x 12d	600 lbs.
42w x 18d	600 lbs.
42w x 24d	550 lbs.
42w x 36d	550 lbs.
48w x 12d	500 lbs.
48w x 18d	500 lbs.
48w x 24d	450 lbs.
48w x 36d	450 lbs.

PERFORATED STEEL SHELVES

UNIT SIZE	WT. CAPACITY
36w x 12d	450 lbs.
36w x 18d	450 lbs.
36w x 24d	450 lbs.
36w x 36d	400 lbs.
42w x 18d	375 lbs.
42w x 24d	325 lbs.
42w x 36d	250 lbs.
48w x 12d	300 lbs.
48w x 18d	300 lbs.
48w x 24d	250 lbs.
48w x 36d	175 lbs.

*Load capacities based on evenly distributed loads
Total unit capacity not to exceed 8,000 lbs.

GENERAL SAFETY INFORMATION

Some parts may have sharp edges. CARE must be taken when handling various pieces to avoid injury. For safety, wear a pair of work gloves when assembling or performing any maintenance on units.

LIMITED WARRANTY

Tennsco warrants goods purchased hereunder to be free of defects in materials and workmanship for a period of one (1) year from the date of shipment, hereunder. This warranty shall not apply in the event goods are damaged as a result of misuse, abuse, neglect, accident, improper application, modification or repair by persons not authorized by Seller, where goods are damaged during shipment, or where the date stamps on the goods have been defaced, modified or removed. UNLESS CONSIDERED UNENFORCEABLE OR UNLAWFUL UNDER APPLICABLE LAW:

- a. ALL IMPLIED WARRANTIES, INCLUDING BUT NOT LIMITED TO WARRANTIES OR MERCHANTABILITY AND FITNESS FOR A PARTICULAR PURPOSE ARE HEREBY EXCLUDED:
- b. BUYERS REMEDY, IF ANY, FOR ANY DEFECTIVE GOODS SHALL BE LIMITED TO A REFUND BY SELLER OR REPLACEMENT OF THE GOODS AT SELLER'S OPTION, AND SHALL IN NO EVENT INCLUDE DAMAGES OF ANY KIND, WHETHER INCIDENTAL, CONSEQUENTIAL OR OTHERWISE.

NO GOODS ACCEPTED FOR RETURN WITHOUT PRIOR APPROVAL. Seller shall have the right to inspect any goods claimed to be defective at Buyers place of business or require Buyer to return the goods to Seller for inspection on Seller's premises. Transportation charges covering returned goods will be borne by Seller only if such goods are proven to be defective, are covered by this warranty and are returned within the warranty period stated above.



PROUDLY MADE IN THE U.S.A.

Tennsco LLC., Dickson, TN 37056-1888 • (866) 446-8686

ASSEMBLY OF STEEL SHELVING

Tools Needed: A rubber mallet for seating the shelf supports into the uprights.

Two people are recommended for assembly. Approximate assembly time: 20-30 minutes per section.

1. The reference numbers used throughout this sheet refer to the illustration on the back cover. This is to help you to identify the various parts as they are mentioned.

NOTE: All illustrations show a solid shelf. Assembly for perforated shelf is identical.

2. Create a unit end by connecting two uprights (Ref. No. 1 or 2) with one of the front-to-back shelf supports (Ref.No. 3) by inserting the shelf support rivets into the bottom two keyhole slots of each upright using a rubber mallet to seat the upright securely in the keyhole slots.

NOTE: Be sure that the narrow end of the keyhole slots are pointing downward, and the flat edge of the shelf support is facing up.

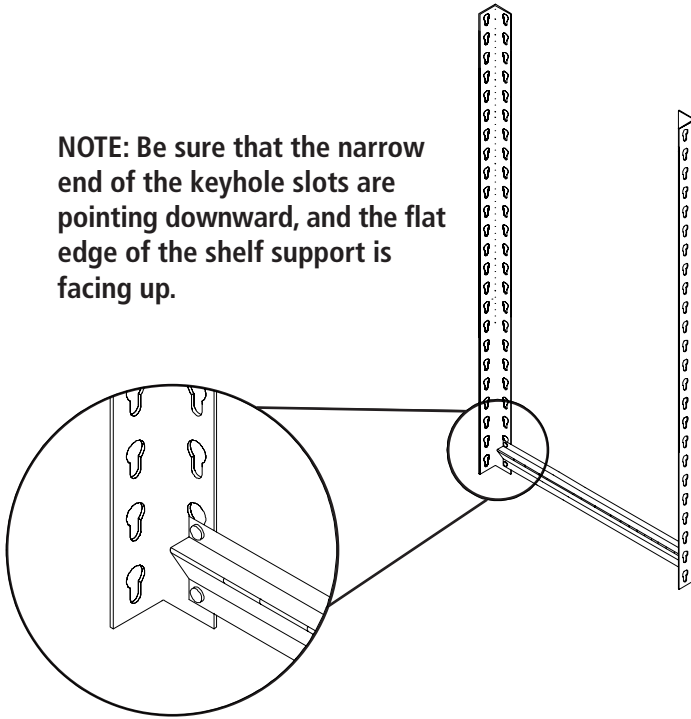

3. Assemble another unit end by repeating the directions in step 2. Be sure the shelf support rivets are seated in the bottom of the slots. If you are creating a starter unit and adder units then you will need to replace the EUR upright post on one end with ZTP upright posts.

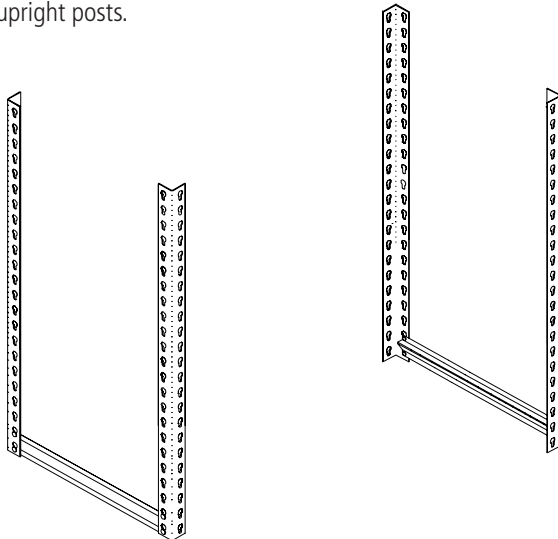

4. Connect two of the left-to-right shelf supports (Ref. No. 4) between the two assemblies, one on each side with angled corners facing toward each other. Be sure to use the two keyhole slots nearest the floor, as in step 1.

NOTE: As in step one, make sure the flat edge of the shelf supports are facing upwards. If this has been done correctly, there would now be a flat surface around all four edges on which to lay the bottom steel shelf.

If any edges have an upward facing angled edge, the support has been inserted upside down.

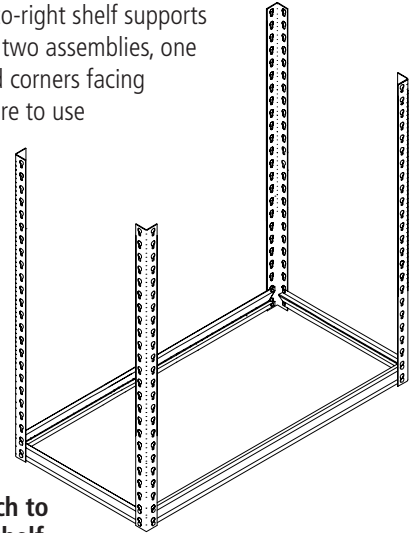

5. Finish installing the remaining left-to-right shelf supports and front-to-back shelf supports around the top of the unit.

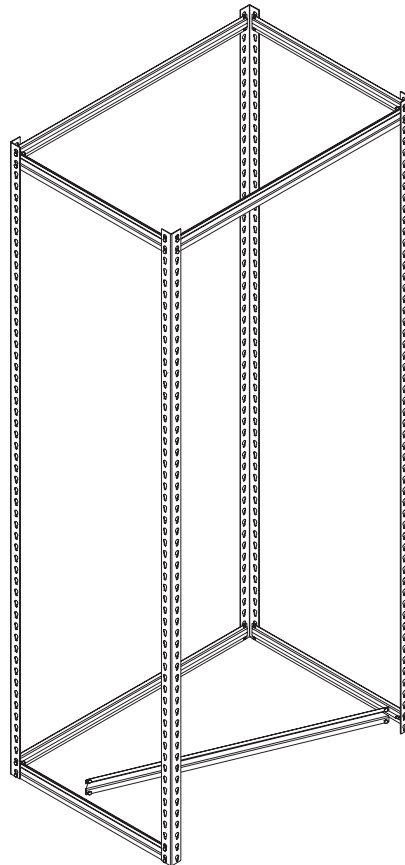

NOTE: Be sure that the support rivets are seated in the bottom of the slots of the uprights securely.

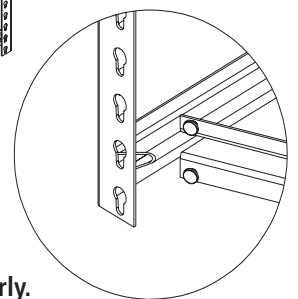

6. After building the framework, place a steel shelf (Ref. No. 5) on the lower level and on the top level of the VDRS supports. These shelves will lay directly on the flat ledge of the support.

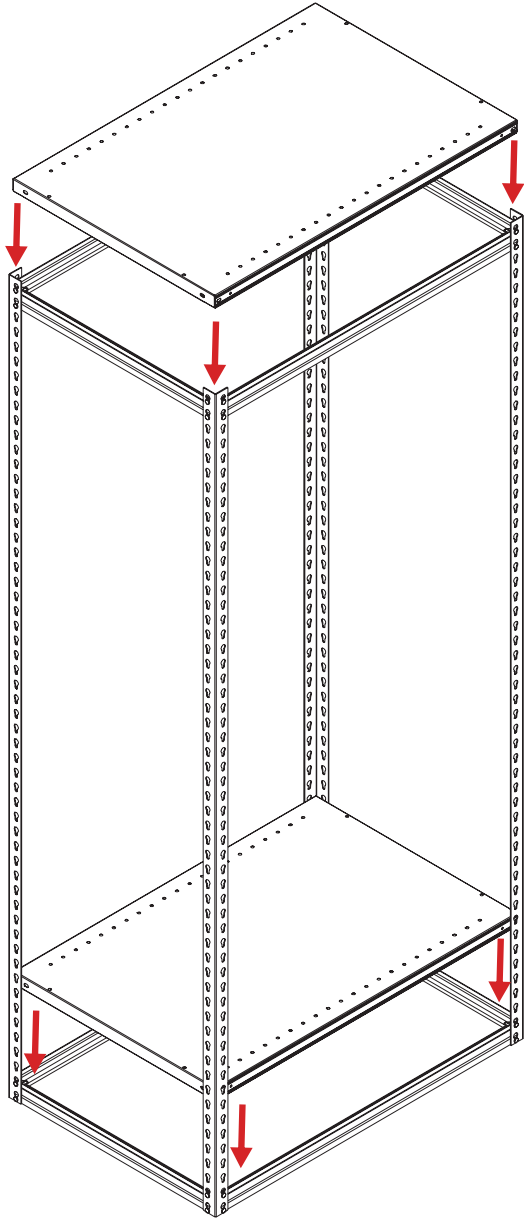

7. Next attach the ZSC-1 shelf clips (Ref. No. 6) to the EUR post as shown. Make sure that all four clips are on the same level on each of the uprights for the shelves to be level. Be sure to drive the clips down until they are seated firmly then install the shelf on top of the four clips, with the shelf sliding into the slot in the clip.

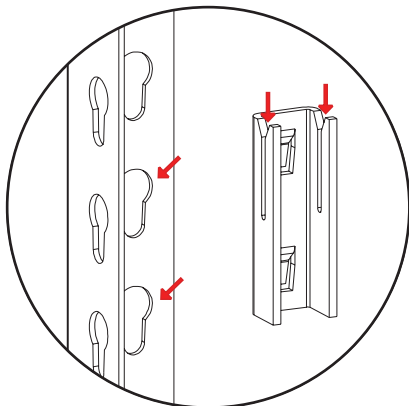

8. If you were assembling a stater unit, your unit is now ready for use and will look similar to the drawing below.

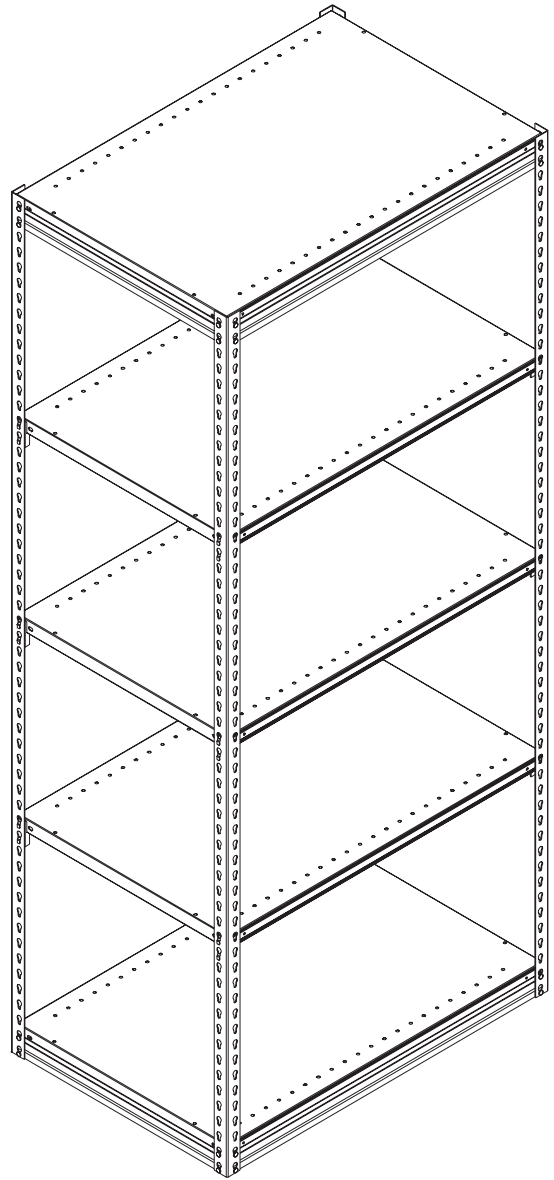

9. If you are assembling an adder unit it will not look like the drawing above. The adder unit will share front and back supports with the starter unit on the side that the starter unit is connected using an intermediate "T" post. To attach an adder unit to a starter unit you will attach the VDRS supports to the ZTP post and construct the adder unit the same way that you did the starter unit.

REPLACEMENT PARTS

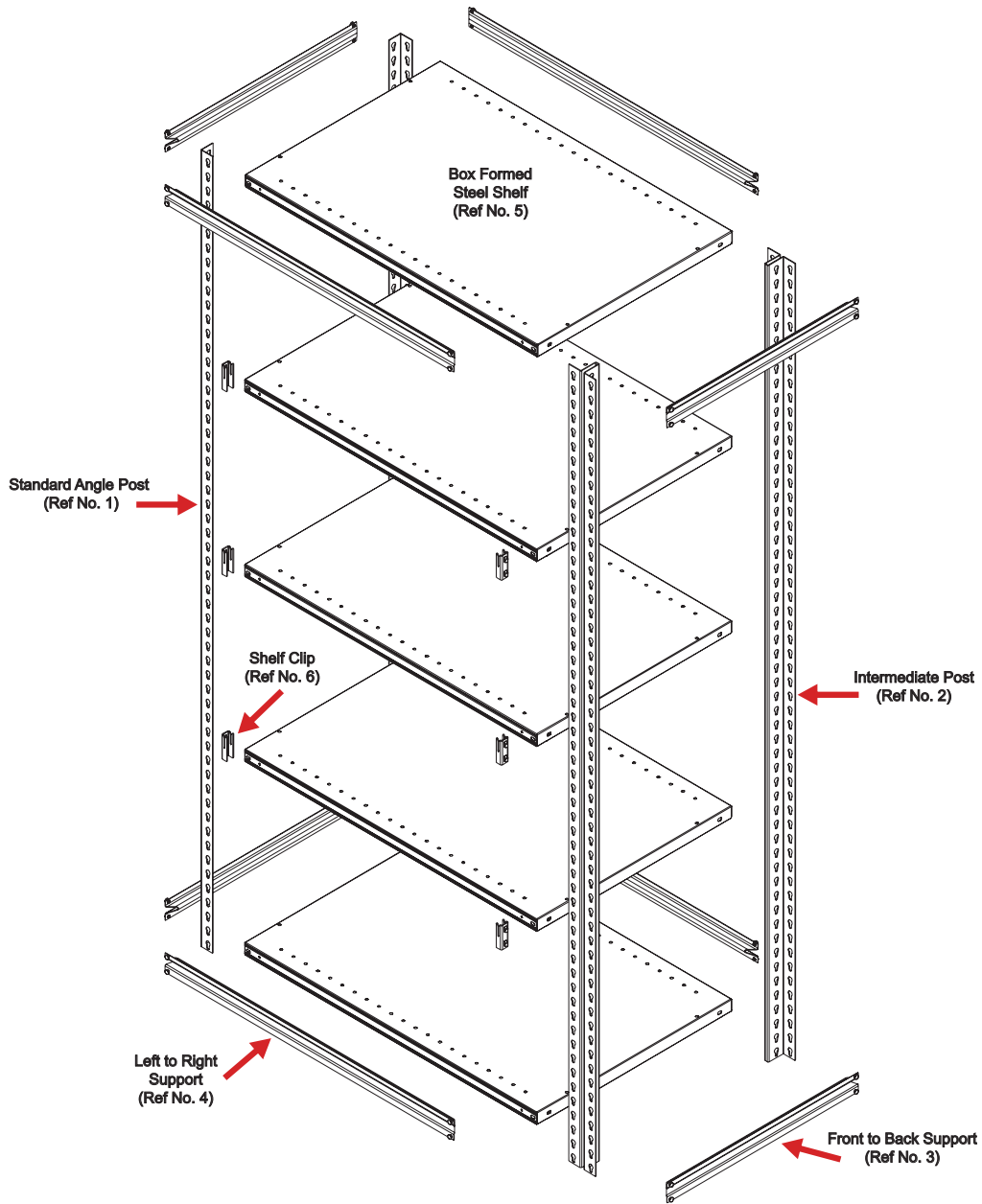

REF. NO.	DESCRIPTION	PART NUMBERS	QTY.	
			STARTER UNIT	ADDER UNIT
1	Standard Angle Post	EUR-84	4	--
2	Intermediate "T" Post	ZTP-84	--	2
3	Front to Back Support	VDRS-ww16	4	4
4	Left to Right Support	VDRS-ww16	4	4
5	Box Formed Steel Shelf OR	ZMS-wwdd	5	5
	Box Formed Perforated Steel Shelf	ZMPS-wwdd	5	5
6	Shelf Clip	ZSC-1	12	12

Tennsco makes every effort to ensure that all units ship complete with all parts and arrive undamaged. However, should your unit contain missing or damaged parts, please contact your purchase location.